

---

# Handling tools

A close-up, high-contrast photograph of a fingerprint on a dark, textured surface. The ridges of the fingerprint are clearly visible, creating a complex pattern of lines and curves. The lighting is dramatic, highlighting the texture of the skin and the surface it's on.

## Drill pipe elevators

> MH drill pipe elevator

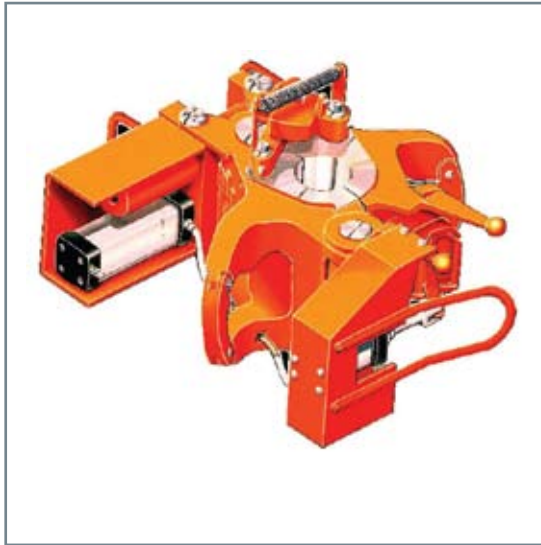

The MH drill pipe elevators are DnV type approved and designed in accordance with API specifications.

The well proven MH drill pipe elevator is pneumatically operated.

5" - rated to 350 tons - weight 550 kg (1220 lb)  
3 ½" - rated to 350 tons - weight 570 kg (1270 lb)

## Power slips frames

> MH power slips frames for drill pipe slips 3"-7" is available

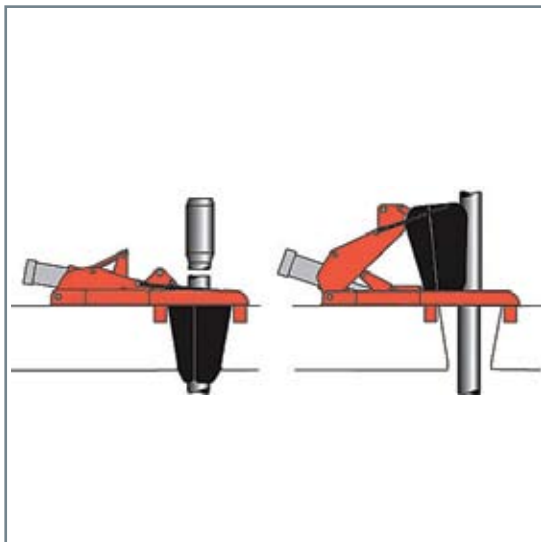

The MH power slips frames consist of a frame with standard slip segments, ranging from 3 ½ in. to 7 in. An air pressure of 7 bar (125 psi) is required for operation. A foot pedal located in the driller's house is used for opening and closing. In combination with the pipe racking system, the result is fast and safe pipe handling.

# Hydraulic rotary tables

> MH hydraulic rotary table



The MH hydraulic rotary tables are based on a standard table for electric drive, modified to include one or four hydraulic motors. Considerable weight and space is saved by installing a hydraulic rotary table instead of an electric one, as the electric motor requires an extended skid for installation of the transmission box, brake assembly and motor. The hydraulic rotary table can be driven by the same power unit as the hydraulic top drive 345 bar system, or can be hydraulically powered from the ringline 210 bar system. Considerable weight and space savings can be obtained for hydraulic power unit(s) if an hydraulically driven drawworks is installed, as these consumers do not require full power at the same time.

## Options

Kits for conversion or electrically driven rotary tables.  
Range: 37 1/2 ", 49 1/2 ", 60 1/2 "